

# INSTALLATION GUIDE FOR THE TYPE AGN PRECAST BASE MOUNTED COMPOSITE LIGHTING COLUMN.

Workplace health and safety regulations

The installation and assembly works should be carried out as set forth in the Regulation of the Minister of Infrastructure of 6 February 2003 on the workplace health and safety during construction works (Journal of Laws No. 47, item 401, of 19 March 2013).



Prepare a pit large enough to accommodate the precast base, as recommended in the table on page 2.

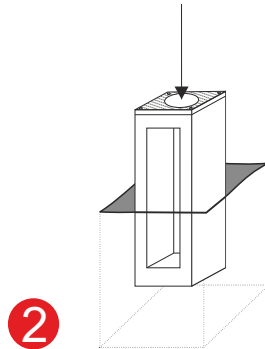

Place the relevant precast base in the pit.

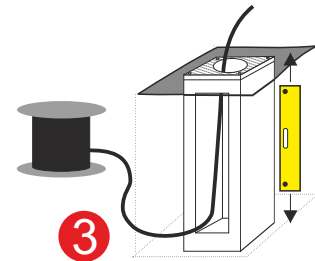

Put the precast base upright and make sure it is perfectly level. Insert the power cord into the hole in the precast base.



Cover up the pit with native soil, thickening it layer by layer with a mechanical earth rammer.

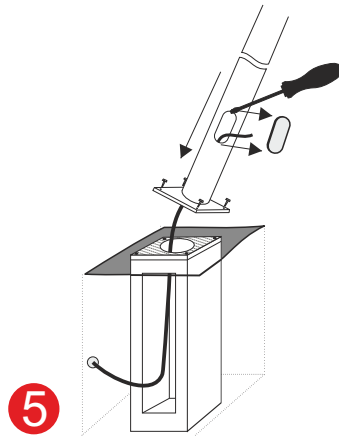

Unscrew the inspection flap and pass the cable through it. Place the column onto the precast base. Use the supplied screws, washers and blind nuts to attach the column foot.

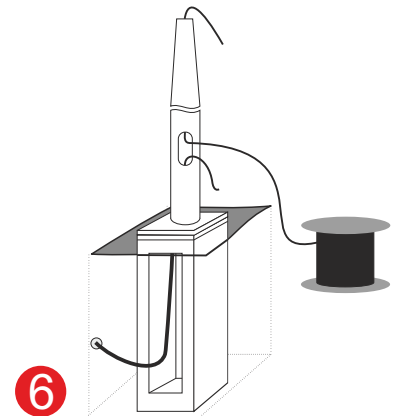

Insert the power cord of the LED luminaire into the hole of the inspection flap and pass it all the way up to the column finial.

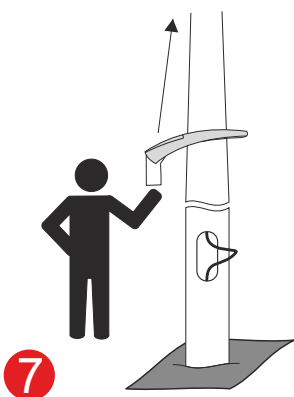

Mount the bracket or LED luminaire (detailed instructions for the assembly and installation of the LED luminaire are supplied together with the product).

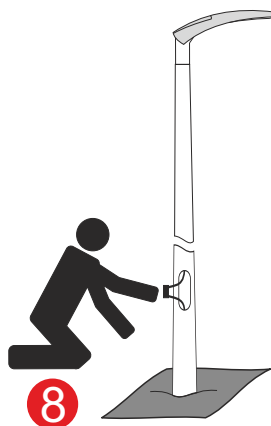

Connect the power cord to the power supply.

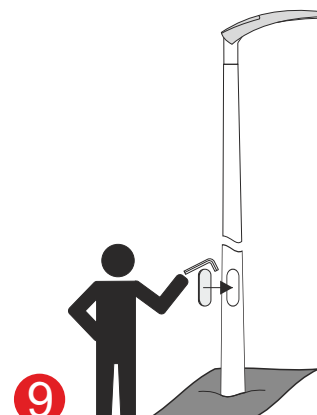

Screw the inspection flap using an Allen key. The column is ready to use.

**Zalecenia producenta:**

Głębokości wykopu zależna od wysokości prefabrykatu.

Typ	Wysokość słupa [m]	Wymiary podstawy słupa [mm]	Rozstaw otworów [mm]	Prefabrykat	Wysokość prefabrykatu [m]	Waga prefabrykatu [kg]
AGN-003	3	295x295	200x200	AF100/200	1.0	140
AGN-004	4	295x295	200x200	AF100/200	1.0	140
AGN-005	5	295x295	200x200	AF100/200	1.0	140
AGN-006	6	295x295	200x200	AF120/200	1.2	160
AGN-007	7	295x295	200x200	AF120/200	1.2	160
AGN-008	8	295x295	200x200	AF120/200	1.2	160
AGN-009	9	295x295	200x200	AF150/200	1.5	200
AGN-010	10	295x295	200x200	AF150/200	1.5	200
AGN-011	11	295x295	200x200	AF150/200	1.5	200

**Akcesoria:**

1. Śruba z wgłębieniem imbusowym z gwintem na całości M20x50 B DIN 912 - 4 szt.
2. Podkładka M20x37x3 B DIN 125 - 4 szt.
3. Maskownica śruby M20 - 4 szt.